

BUILT-IN TYPE

SBT Model



Big Size Built-in Model

- Suitable for Big Machine Motors.
- Mountable for The Shaft 14~ 26 mm.

Model

SBT - [] - [] [] - [] [] - **050-01**

Resolution

Output Mode

Hollow Shaft Diameter

- 14 : 14
- 16 : 16
- 19 : 19
- 20 : 20
- 24 : 24
- 26 : 26

- No Indication : Voltage Output
- C : Open Collector Output
- D : Line Driver Output

Signals — 2M : AB90° Phase Difference + Zero Signal

01	100 P/R	05	500 P/R	10	1000 P/R
02	200 P/R	0512	512 P/R	38	3800 P/R
036	360 P/R	06	600 P/R		

External Dimension

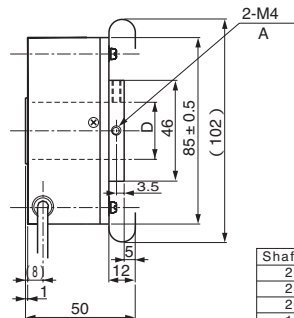
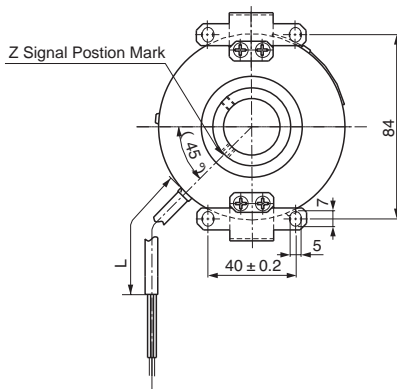

Shaft No	D	Screw Diameter	A
26	26H7	M4 x 5	
24	24H7	M4 x 5	
20	20H7	M4 x 8	
19	19H7	M4 x 8	
16	16H7	M4 x 10	
14	14H7	M4 x 10	

Circuit of Output Signal

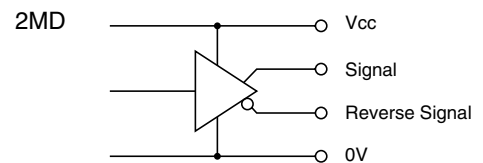
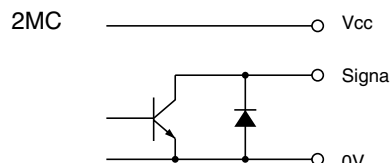
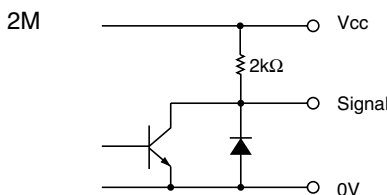

Electrical Spec.

TYPE		2M	2MC	2MD
Supply Voltage		DC 4.5 ~ 13.2 V		DC 4.5 ~ 5.25 V
Requirement		80 mA Max	60 mA Max	150 mA Max
Output Voltage	“H”	Within -1 Power Volt	—	2.5 V or More
	“L” ※1	0.5 V Max		
Maximum Output Current		20 mA MAX		
Rise & Fall Time		1 μs Max		200 ns Max
Maximum Frequency Response		200 kHz		
Withstanding Voltage of Output Tr.		—	50 V MAX.	—

※1) at Maximum Output Current

Wave Form.

CW → Rotating Toward Clockwise Viewed from an Arrow

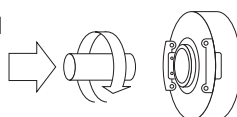

Rising point of A-Signal is always at one point while Z-Signal is at H-Level in CW.

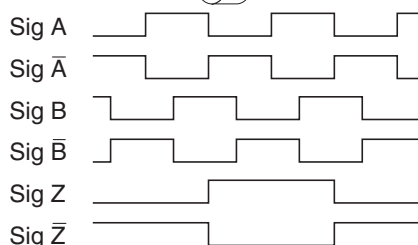
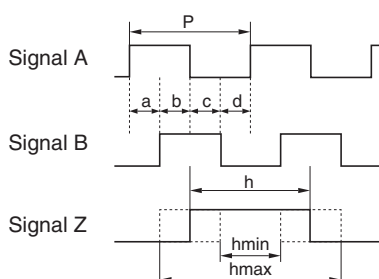

$$P = \frac{1}{1 \text{ Resolution}}$$

$$a, b, c, d = \frac{P}{4} \pm \frac{P}{8} \quad \frac{P}{2} \leq h \leq \frac{3P}{2}$$

Wave Ratio (Duty); 50 ± 25 (%)

Electrical Connections

2M
2MC

Color of Lead Wire	Description
Red	Power Source
Black	0V Common
Green or Blue	Signal A
White	Signal B
Yellow	Signal Z
Shielding Braid	NC

2MD

Color of Lead Wire	Description	Color of Lead Wire	Description
Red	Power Source	White	Signal B
Black	0V Common	Gray	Signal B
Green	Signal A	Yellow	Signal Z
Blue	Signal A-bar	Orange	Signal Z
Shielding Braid	NC		

Mechanical Spec.

Starting Torque	19.6X10 ⁻³ N · m Max	
Angular Acceleration	1X10 ⁴ rad/s ²	
Shaft Loading	Thrust axial	19.6N
	Radial	29.4N
Moment of Inertia	8X10 ⁻⁵ kg · m ²	
Maximum RPM	3600r/min	
Net Weight	1kg Max	

Environmental Spec.

Operating Temperature	-10°C ~ +50°C : 3600r/min +70°C : 3000r/min
Storage Temperature	-20°C ~ +80°C
Humidity	RH 85% Max No Condensation
Vibration	10~55 Hz / 1.5mm 2 h
Shock	490m/s ² , 11ms X, Y, Z Each 3 times